

1.

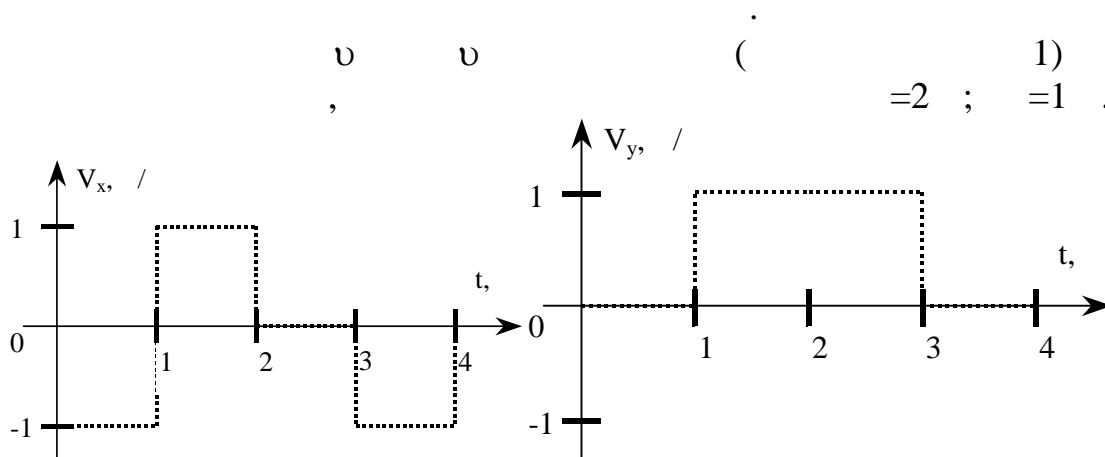

2.

(      .      «      »).

$t_1 = 10$

$\ddagger = 10$  ,

?

3.

1.      ,      2,       $U = 100$  ,       $R = 10$

$U_1 = 49,75$  .

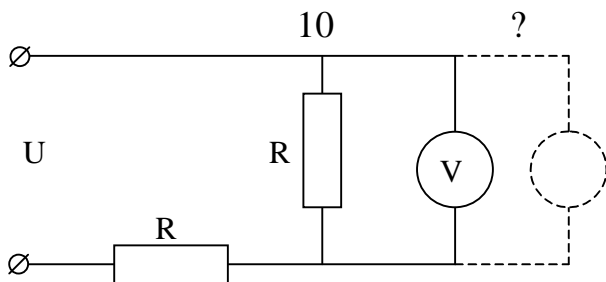

4.

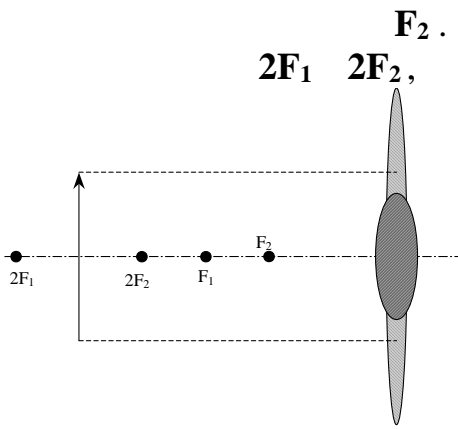

$F_1$

5.