

, ,
()

(« 8-9 »)
2013-2014

- 45

- 25 (_____) .

I. ()

1.) ; ...
) ;
) ;
) ;
- 1 - .

2.) ; ...
) ;) ;
) ;) ;
- 1 ;) .

3.) ;) ;) ...
- 1) ;) .

4.) ;) ;) ...
) ;) ;) ;
- 1) ;) .

5.) ; - 1) ;) , ...
- 1) ;) .

6. ... ;
) ;
)
)
 -1

7. , : , , ,
) ; ”) ... ;) ..
 -1

8.) 0,2 0,5 ;) 0,1 0,2 ;) 0,2 ... 0,3 ;) 4,0 0,6 .
 -1

II. — — ()

9. - ;) - ; :
) ; ;)
)
 -1

10. :
) ;) ;
) ;)
 -1

11. ,
) ; :) ;)
 -1

12. :
) ; ;
) ;
) ;
)
 -1

13.) ;) ;) ;) ;
) ;) ;) ;) ;
 - 1

III. ()

14. _____ - , , .
 , - 1 , , .

15. ,
 _____.
 - 1

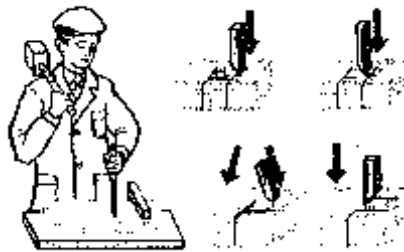

16. - _____
 - 1

17. , ,
 _____,
 - 1

18. - _____,
 _____,
 - 1

19. - _____



- 1

IV.

20. _____ :

1.)
2.)
3.)
4.	())





- 1

21. _____ :

1.)
2.)
3.)
4.)
5.)

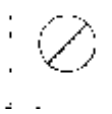
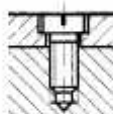
- 1

22. _____ :

1.	)	
2.	)	
3.	)	

- 1

V.

23.

) ;) ; :) ;) .
- 1

VI.

24. _____ , _____ :

1. _____
2. _____

3. _____
- 1

25. _____ :
1. _____
2. _____
3. _____
- 1

1. _____ ,



: - _____ , - _____ , - _____
- 3 (_____)

2. _____ :



: _____
- 2