

65*60 : S = 3
 : 3

1

2

3

4

1

2

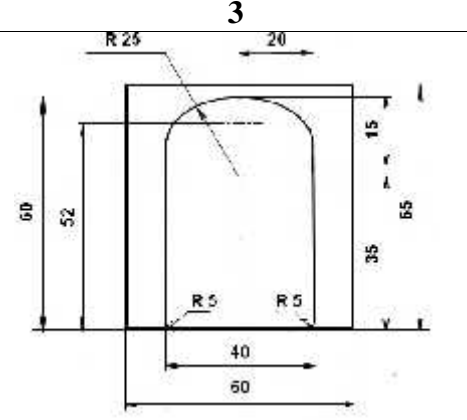

5

2

5
2
10

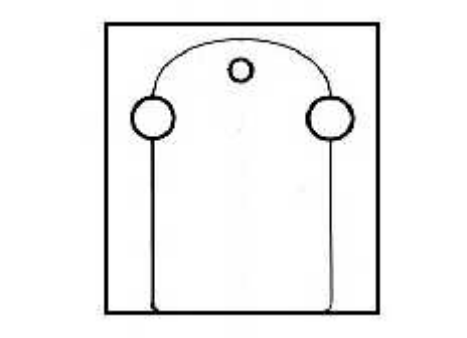

5 10

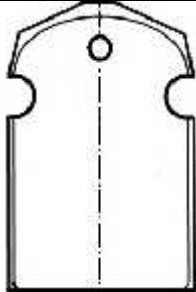
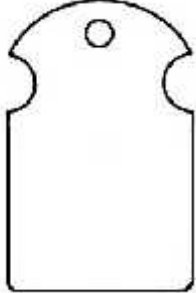
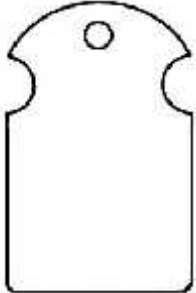
3	(0,5)		,
5			,
6			0. , 3,

\		
1		10
2		5
3		5
4		10
5		5
6		5
	:	40

- 1.
- 2.



:

«

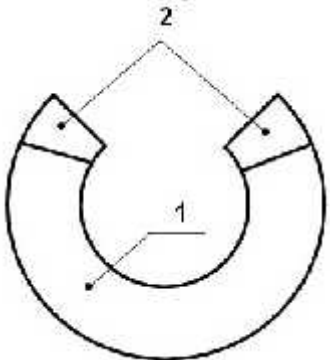
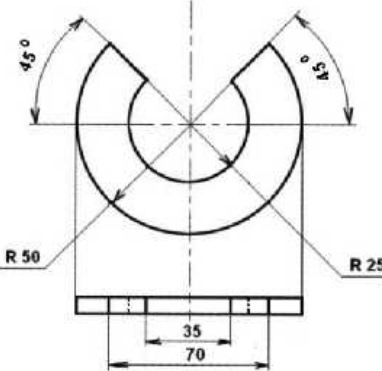
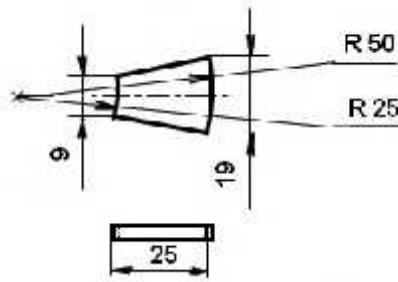
»

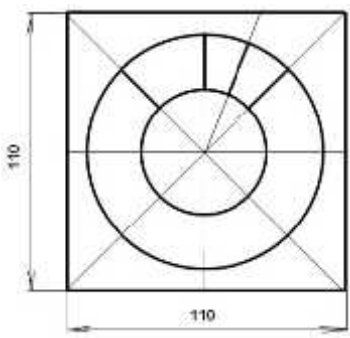
	<p>: 110 110 : 5 .</p>
<p>1</p>  <p>2</p> 	<p>1 – ; 2 – ;</p>

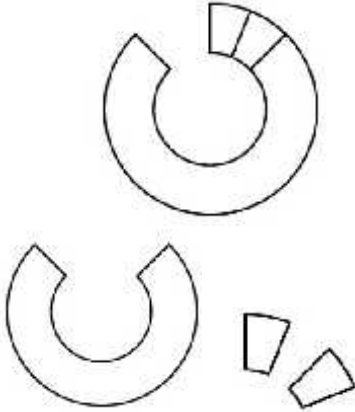
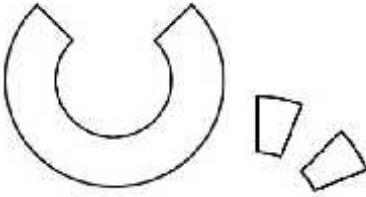
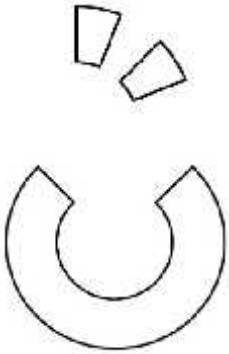
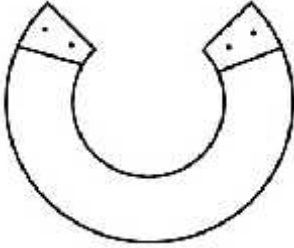
				,
1	2	3	4	5
1, 2	1			,

2	(1).		,
3			:
4			3, 0 32,
5			, L-10 .
6			,

/ 10 /				
1				
2				
3				
4				
5				
6				
7				
8				
9				
10				
11				
12				
/ 25 /				
1				
2				
3				
4				
/ 15 /				
1				
2				
3				
4				
5				
6				
7				
8				
50				