

« »

8

3, S = 3 . 65 * 60 .
 3, 0 , , 5 .

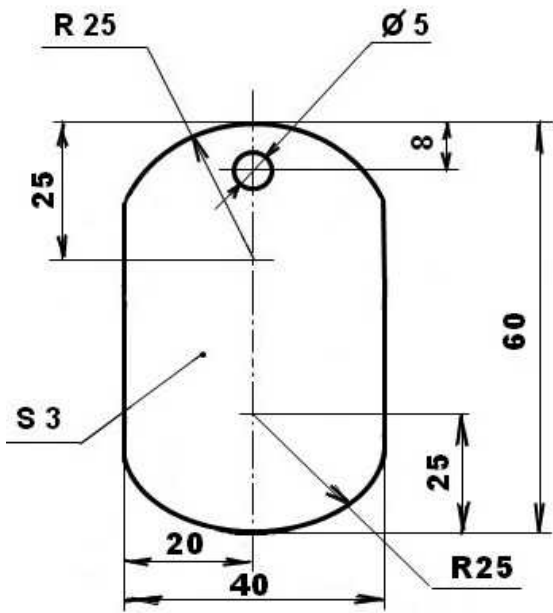

.1



.2

1.) (.1);
)
)

\		
1		10
2		5
3		5
4		5
5		2
6		5
7		3
8		5
		40

1.

2.

0,5

			<p>65*45 : S = 3</p> <p>: 3</p>
<p>1</p>	<p>2</p>	<p>3</p>	<p>4</p>
<p>1</p>			<p>,</p> <p>,</p> <p>,</p> <p>,</p> <p>.</p>
<p>2</p>			<p>5</p> <p>,</p>

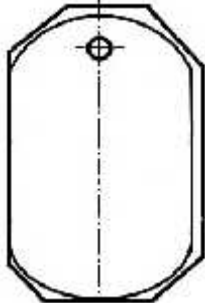
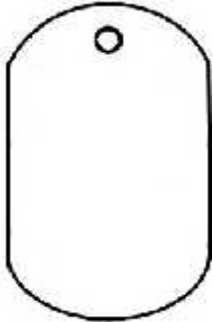
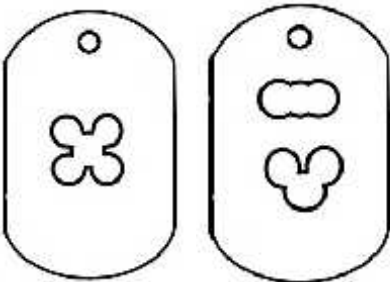
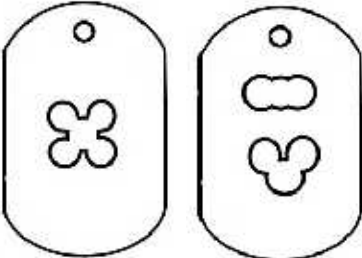
3			,
4			,
5			,
6			0. , 3,

«

»

8

:
: S=5 ; 65 60.
: , 32, 3, 0, , , ,
5 10 ,

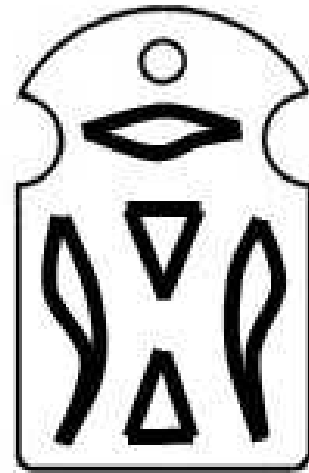
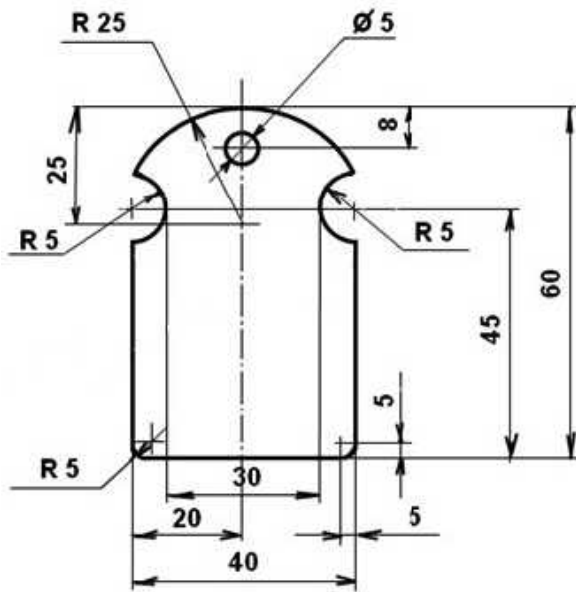

.1

2. :
) (.1);
:
) ;
)



\		
1		10
2		5
3		5
4		10
5		5
6		5
	:	40

1.
2.

:

1 .

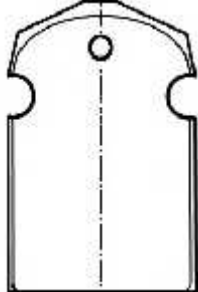
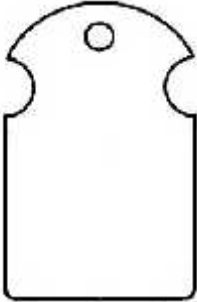
		<p>: 65*60 .</p> <p>: 5 .</p>	
1	2	3	4
1			<p>,</p> <p>,</p> <p>,</p> <p>.</p>
2			<p>10 .</p> <p>5 .</p>

3			<p>,</p> <p>,</p> <p>.</p>
4			<p>,</p> <p>3,</p> <p>0.</p>
5			<p>.</p>

«

»

8

– 50

/ 10 /				
1				
2				
3				
4				
5				
6				
7				
8				
9				
10				
11				
/ 25 /				
1				
2				
3				
4				
/ 15 /				
1				
2				
3				
4				
5				
6				
7				
8				
		:		

