

2015-2016

« - »



7-8

« »

150 x 250 ,

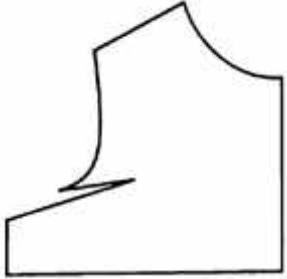
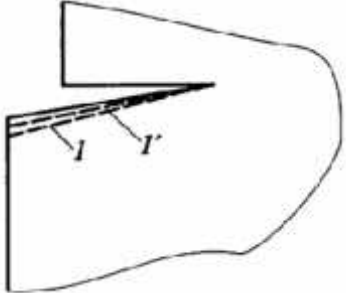
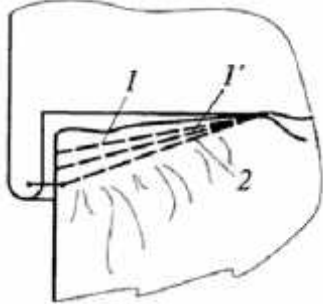
-45 .

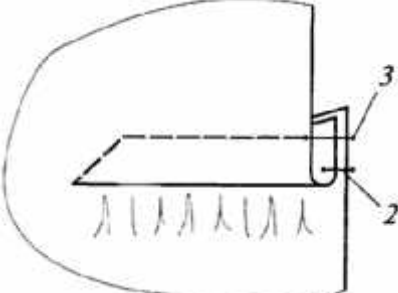
<p>1. - , . , , ( , ).</p>	
<p>2. 1 1<sup>I</sup> 5 . , , .</p>	
<p>3. , . 10 . ( 2).</p>	

<p>4.</p> <p>( 3).</p> <p>2</p>	
<p>5.</p>	

«

-

»

7-8

«

»

5

,

,

,

,

,

.

-45

.

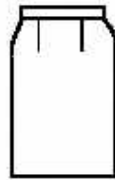
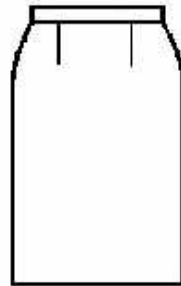
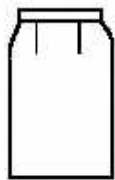
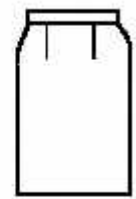
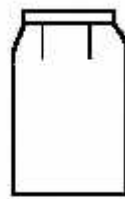
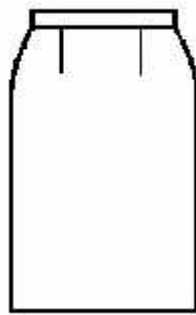
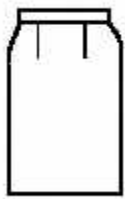
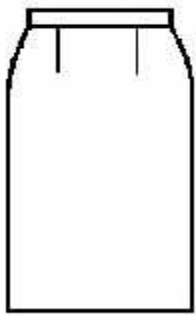

- 1.
- 2.
- 3.
- 4.
- 5.

«

».

Чертеж в М 1:4 для моделирования

