

2015-2016  
7-11

« »

7-8

: 90



- 1.
- 2.
- 3.
- 4.
- 5.

( )

1:1.  
(S) 4  
160 40 4.

±2 ,

±1 .

: 90

- 1.
- 2.
- 3.
- 4.
- 5.

140 100 5.  
1:1.

: 90

: 90

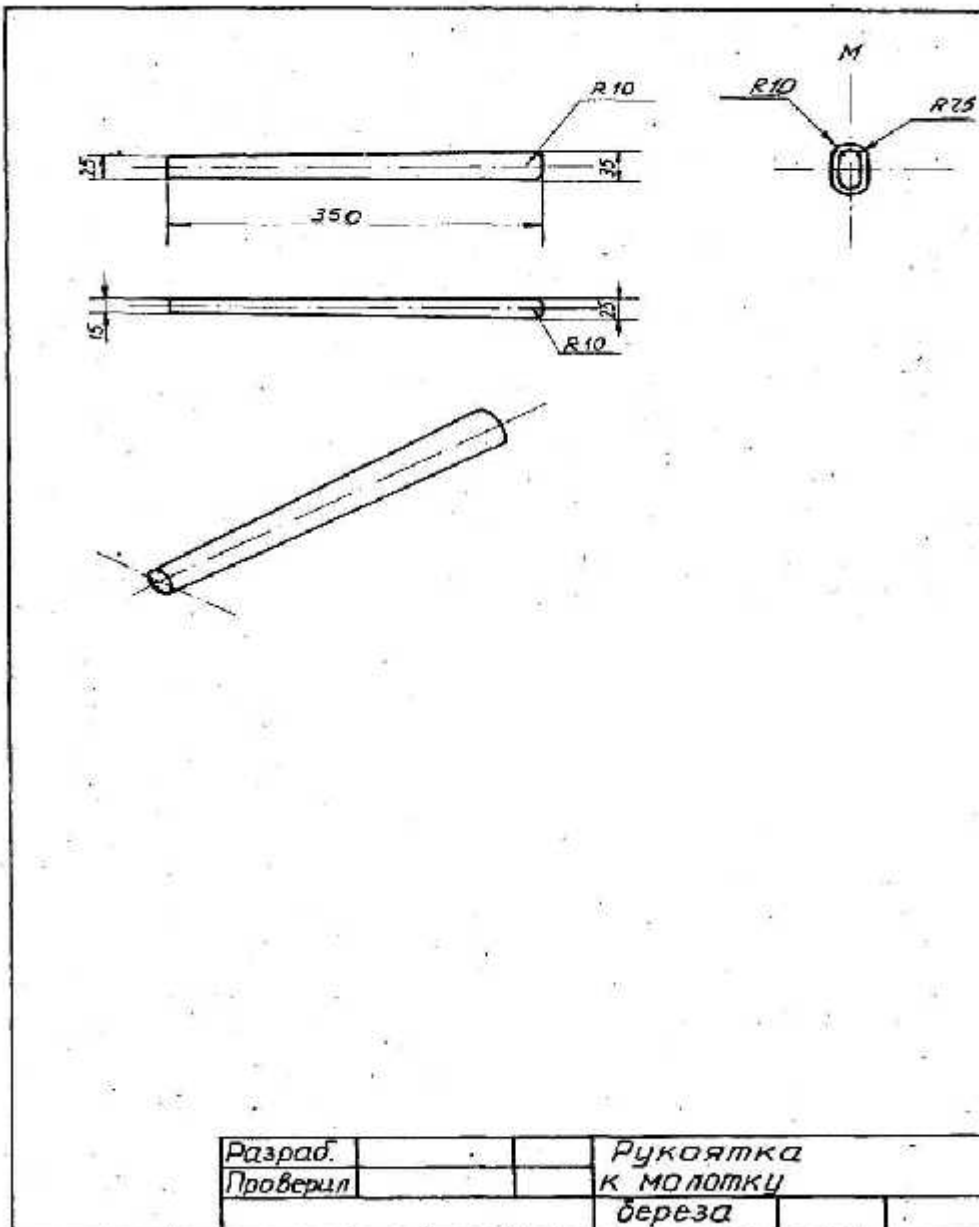

: -120

: 90

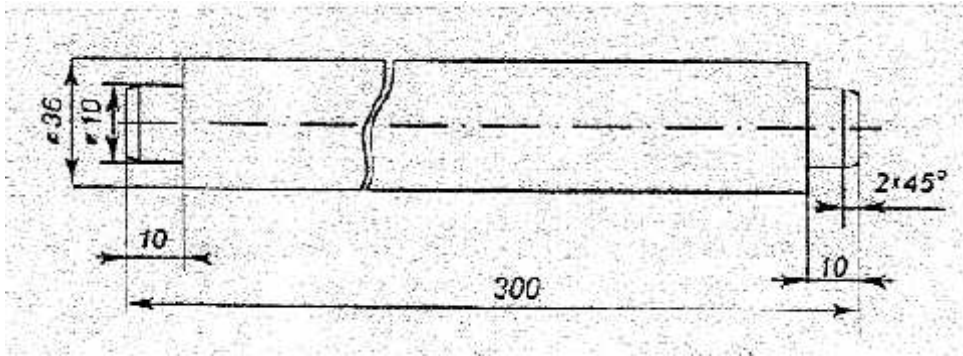

( )

( )

- 1.
- 2.
- 3.
- 4.
- 5.
- 6.

3. (S) - 1

( )

06

$\pm 1$

: 90

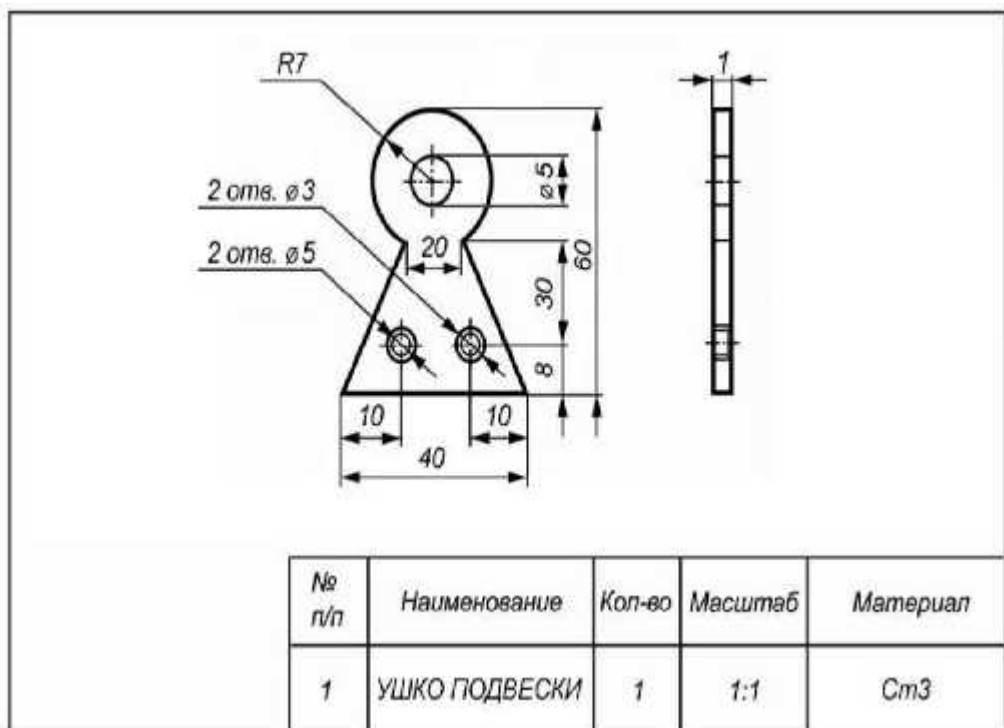

: ± 0,5

: 90

: ± 0,5

: 90

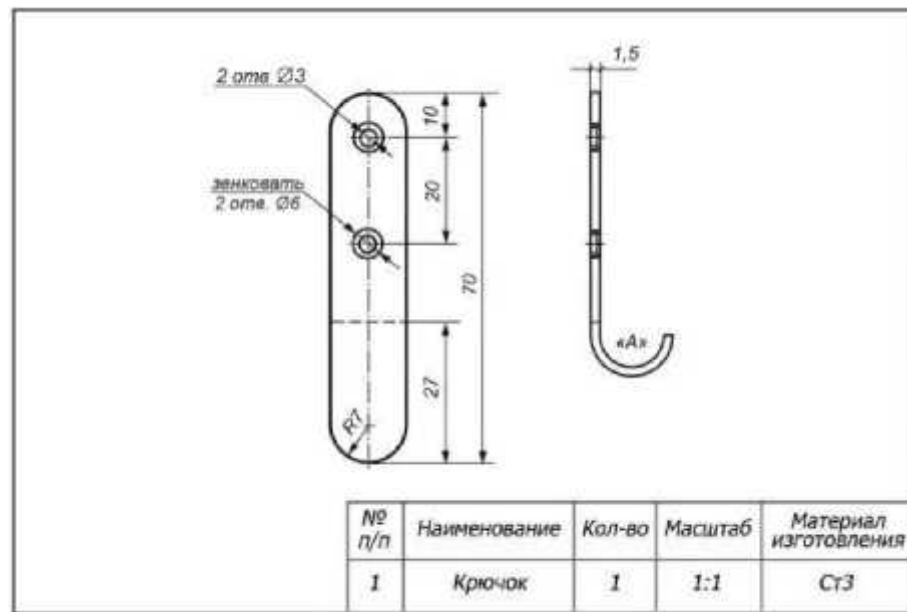

: 1.

- 2.
- 3.

±1

: 90

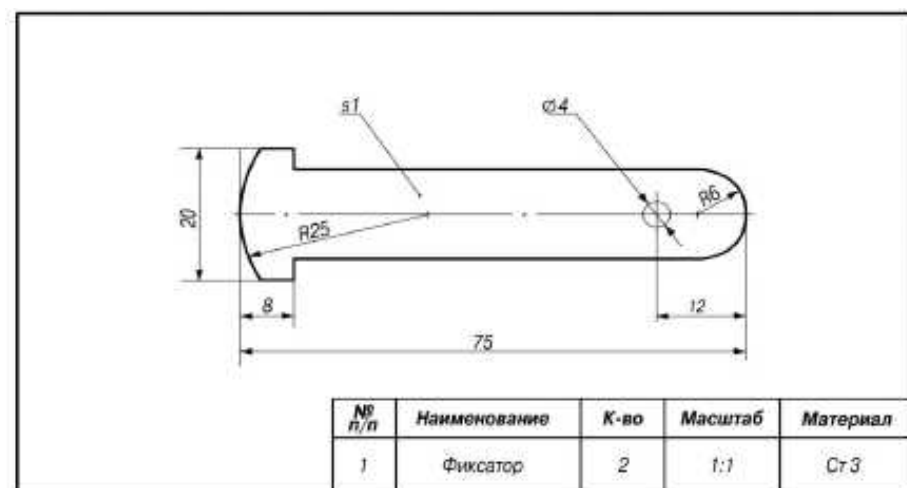

2014-2015  
7-11

« »

7-8

- 1.
- 2.
- 3.
- 4.

: 90