

«

»

3, S=3 . 45*105
 (, (), , ,), , 3, 0.

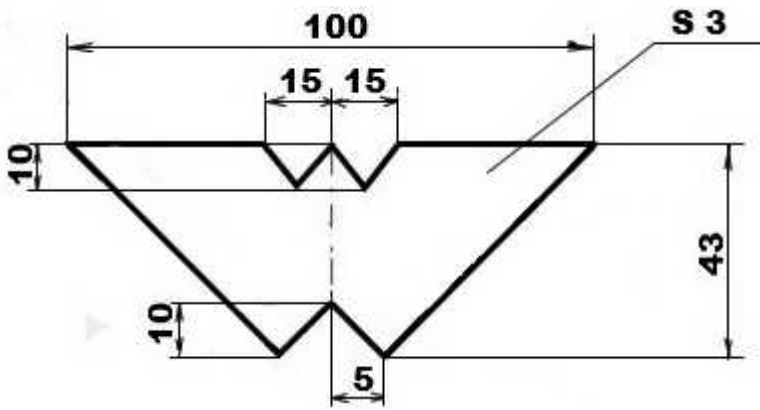

1.) ;
2.)

| | | |
|---|---|----|
| \ | | |
| 1 | | 10 |
| 2 | : | |
| - | | 5 |
| - | | 5 |
| - | | 5 |
| - | | 5 |
| - | | 5 |
| - | | 5 |
| | : | 40 |

1. .
 2. .
- : ±0,5 .

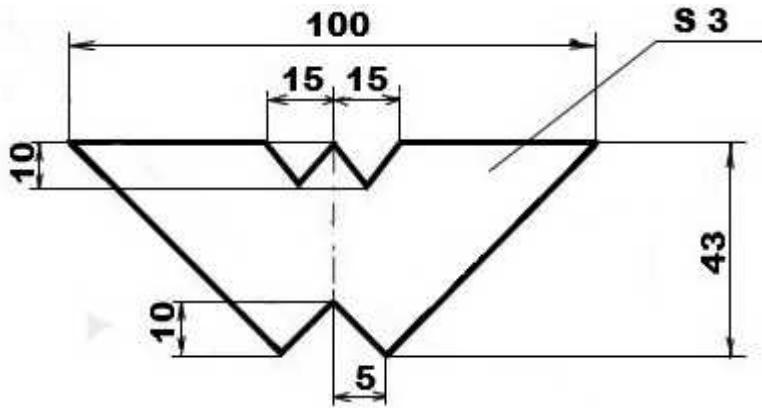

45*105 :S = 3
 .
 : 3

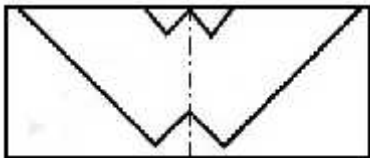
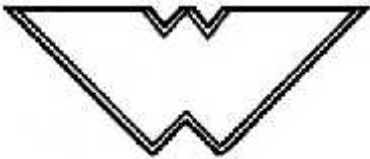
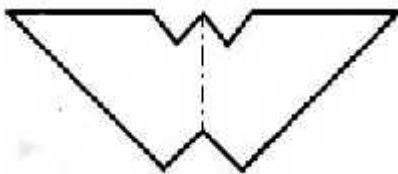
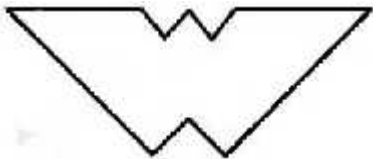
| 1 | 2 | 3 | 4 |
|---|-----|--|-------------|
| 1 | |  | |
| 2 | () |  | |
| 3 | |  | (,) , () |
| 4 | |  | 3, 0 |

« () »

9

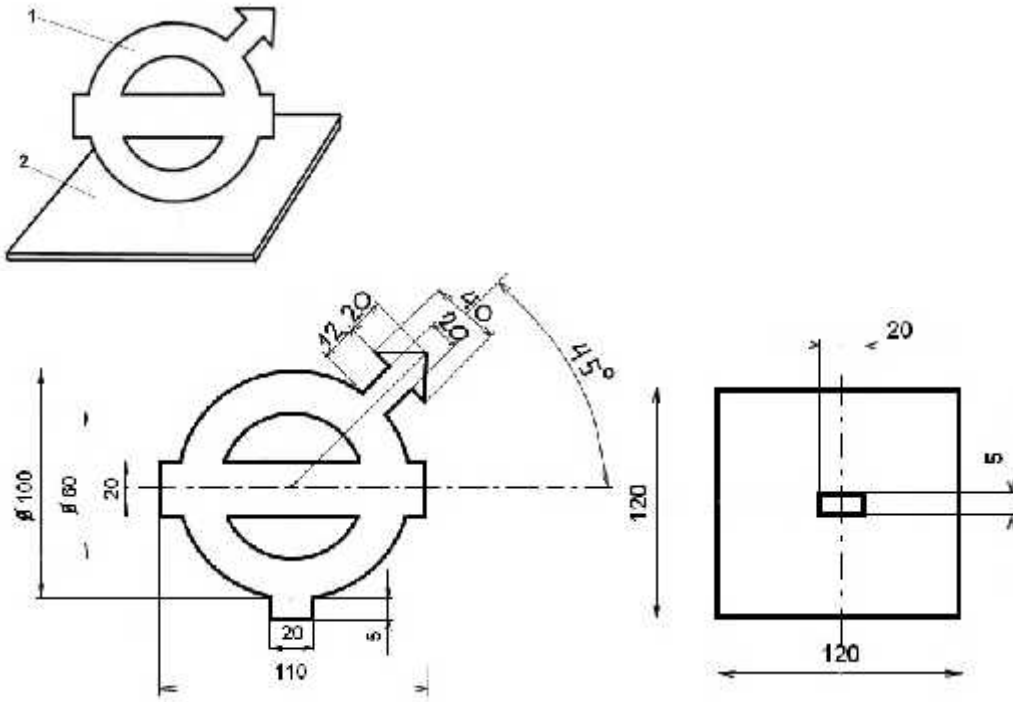

: 2
- (5) 130*130

3, 0,

1.) ;
2.) ;
-)

32,

| | | |
|---|---|----|
| \ | | |
| 1 | | 10 |
| 2 | : | |
| - | | 5 |
| - | | 5 |
| - | | 5 |
| - | | 5 |

| | | |
|--|---|------|
| | - | 5 |
| | - | 5 |
| | | : 40 |

- 1.
- 2.

+ 1 .

| | | | | |
|----------|----------|----------|----------|--|
| | | | | <p>: 2 130*130 .</p> <p>: 5 .</p> <p>1 - 2 -</p> |
| | | | | |
| 1 | 2 | 3 | 4 | 5 |
| 1, 2, | 1 | | | , , , , |

| | | | | |
|---|---|--|--|----------|
| | | | | |
| 1 | 2 | | | , , , |
| | 3 | | | : , , |
| | 4 | | | 32; 3; 0 |
| | 5 | | | , , , |
| 2 | 6 | | | : |
| | 7 | | | 32; 3; 0 |

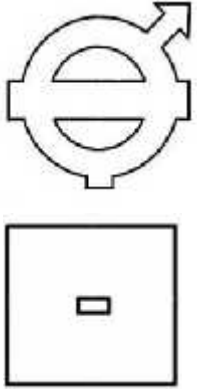
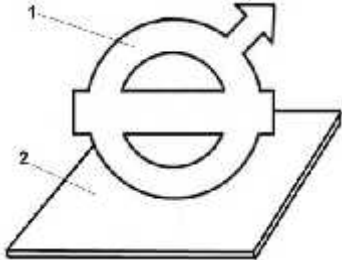
| | | | | |
|-------|---|-----|--|----------|
| 1, 2, | 8 | « » |  | 32; 3; 0 |
| | 9 | - |  | , |