

:

:90



:

()

:90

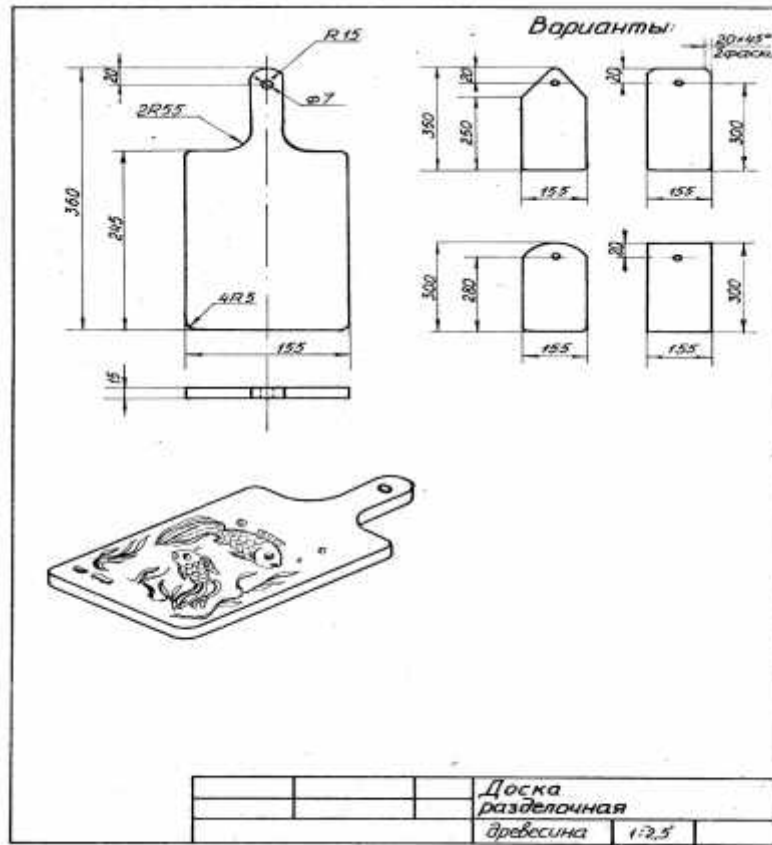

1. : : 1:1;
 - - 5 ;
 - - 160x70;
 - - 03 , 10x10
 ;
- 2.
3. : ±1
 : 90

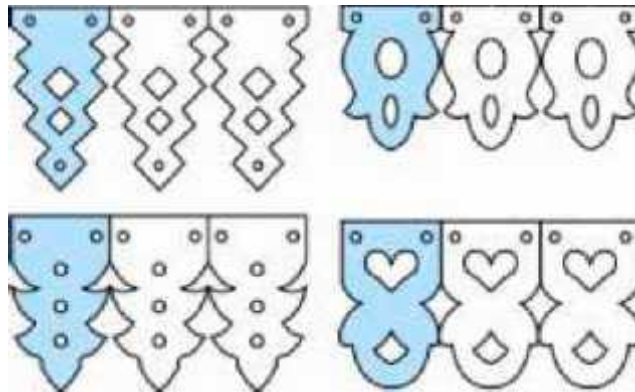

:-120

: 90

(S 2,0)

: 90

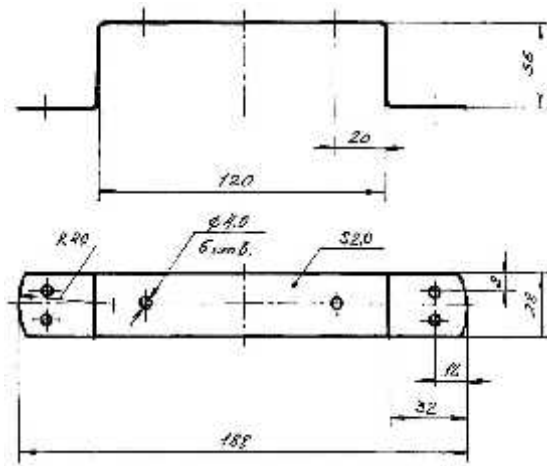

: 1.

- 3.

2. « »
- 3.

:- ± 1 ,

(

) ± 0,5

0,8-1

- 4.
- 5.

: 90

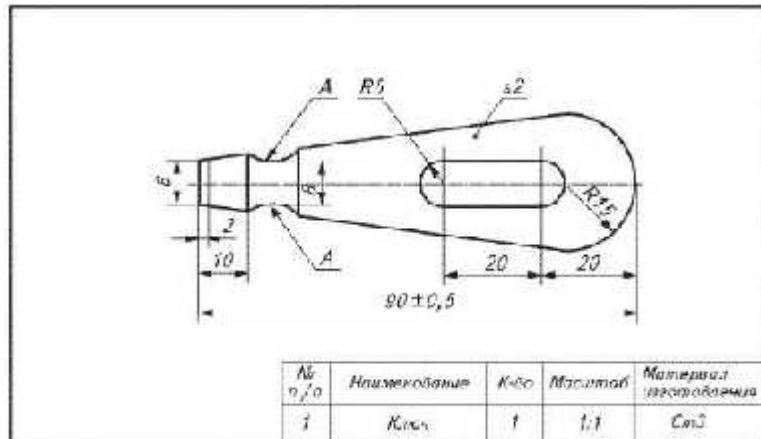

№ п/п	Наименование	Класс	Масштаб	Материал изготовления
1	Клещ	1	1:1	Ст3

: 90

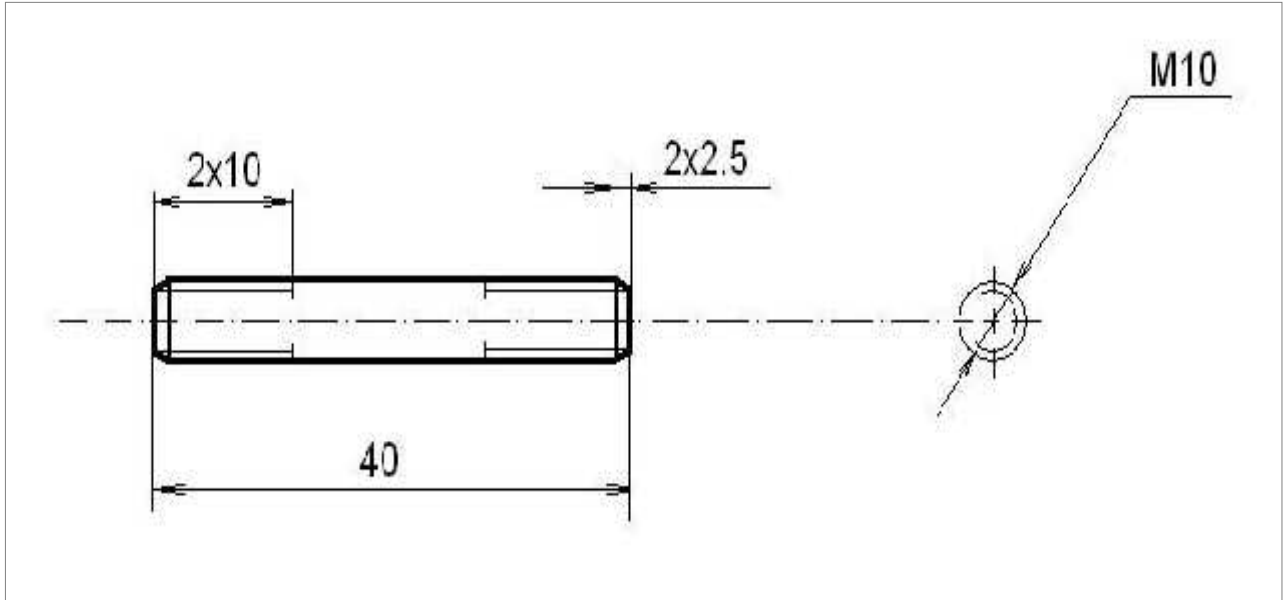

2014-2015
7-11

«

»

9

1.

.

2.

3.

4.

5.

.

: 90