

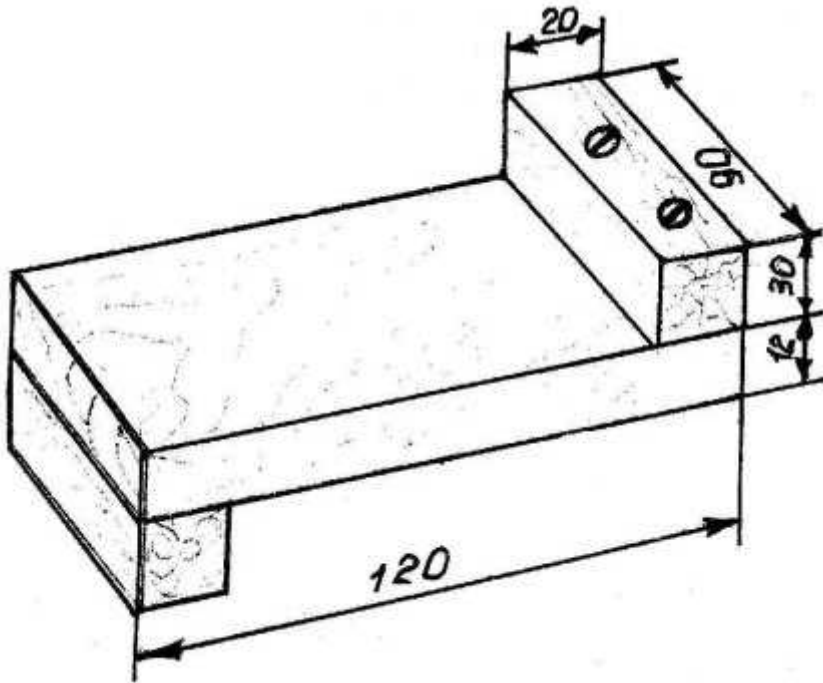

7

« »

- 1.
- 2.
- 3.



1. -2
 2. -3
 3. -20
 4. $(\pm 1) - 10$
 5. -5
- 40