

II ()

10-11

-45 .
2 ;
-0 .

1.

- 1. - , - ,
- 2. - ,
- 3. -

- 2

2;

2.

: 19
 - 40 %, - - 16 %, - 14,8 %, : C - 27,8 %,
 - 60 %.

- 2

;

3.)

· , ·

- 2

4.

« + »

- , :
-)
-)
-)
-)
-)

- 2

: , .

5.

| | |
|----|-----------------|
| 1. | — , |
| 2. | — , (, , . .) |
| 3. | — , (, , , ,) |
| 4. | — () () |

-2

: 1 , 2 , 3 , 4

6.

«+»

-)
-)
-)
-)
-)

-2

: , , .

7.

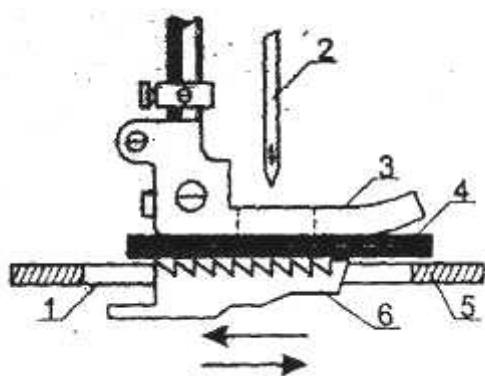

- игла;
- игольная пластина;
- отверстие в игольной пластине;
- прижимная лапка;
- зубчатая рейка;
- сшиваемый материал.

-2

: , , .

8.

)
)
)
)

-
- 2

9.

:

,)
)
) II
)
)
)

- 2

10.

)
)
)

- 2

11.

« + »

- 1.
- 2.
- 3.
- 4.
- 5.

- 2

: 1,2,4,5.



12.

« + »

:
)
)
)

- 2

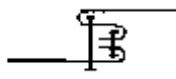
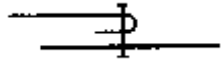
13.

| | | | |
|---|--|--|---|
| 1 | | |  |
| 2 | | |  |
| 3 | | |  |

| | | | |
|---|--|--|--|
| 4 | | | |
| 5 | | | |

: 1-..., 2 -..., 3 -..., 4 -..., 5 -...

-2

: 1- , 2 - , 3- , 4- , 5- .

14. . +

- ...

1. - ;

2. - ,

;

3. -

, , , , , , , ;

4. -

, , , , , , , .

5. -

, .

-2

:3.

15.

. :

- ...; - ...; - ...; -

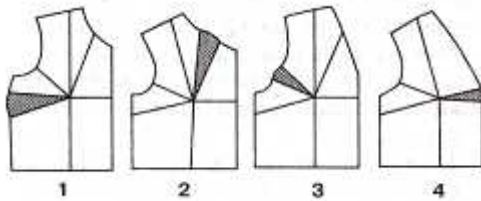

-2

-4, -2, -1, -3

16.

5000 . 10 18% .

-2

: 5750

17. +

1 - □ -

2 - □ -

3 - □ -

4 - □ -

: 3.

18.

| | |
|----|---------|
| | |
| 1. |) , , |
| 2. |) , , , |
| 3. |) , , , |
| 4. |) , , , |

: 1 -, 2 -, 3 -, 4 -

- 2

: 1- ; 2- ; 3- ; 4- .

:

19.

30-40-

XIX

?

- 2

:

20.

?

- 2

:

