

2014-2015

«

»

7-8

:90



- 1.
- 2.
- 3.
- 4.
- 5.

1:1.

(S) 4

160 40 4.

:

±2

,

±1

:90

- 1.
- 2.
- 3.
- 4.
- 5.

140 100 5.
1:1.

: 90

: 90

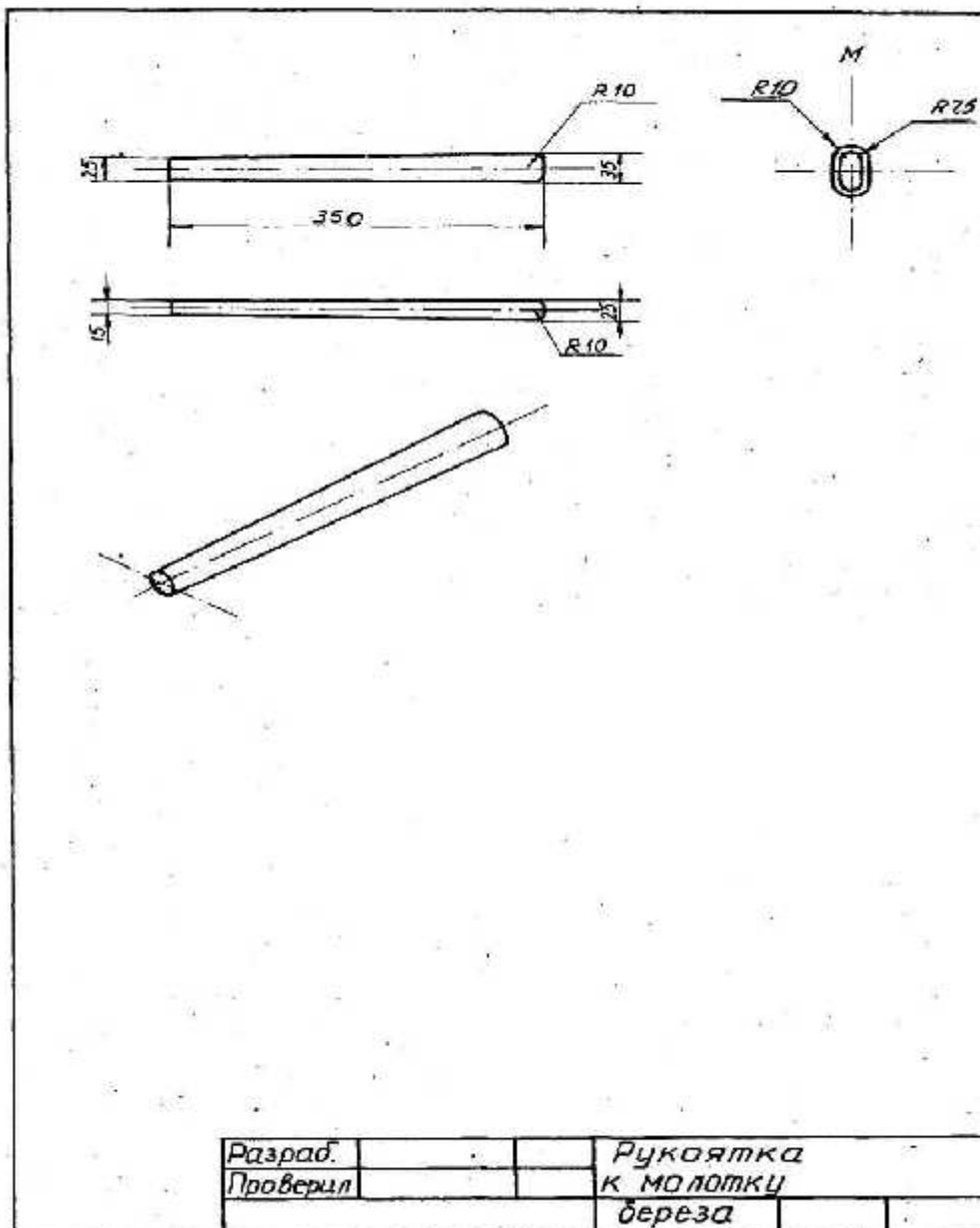

: -120

: 90

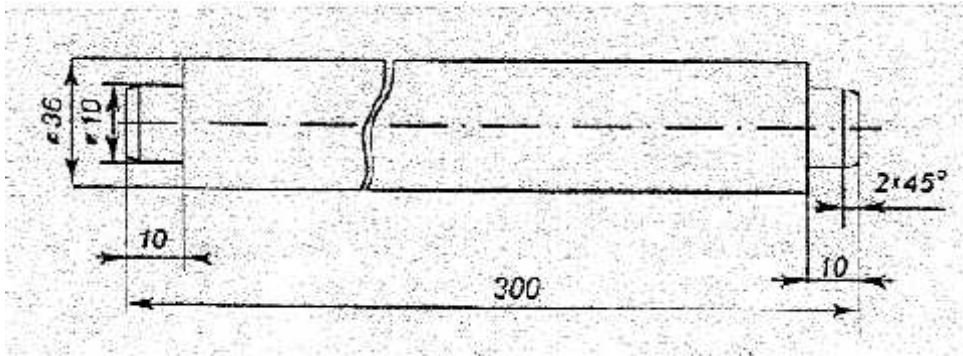

()

()

- 1.
- 2.
- 3.
- 4.
- 5.
- 6.

3. (S) - 1

()

0 6

± 1

: 90

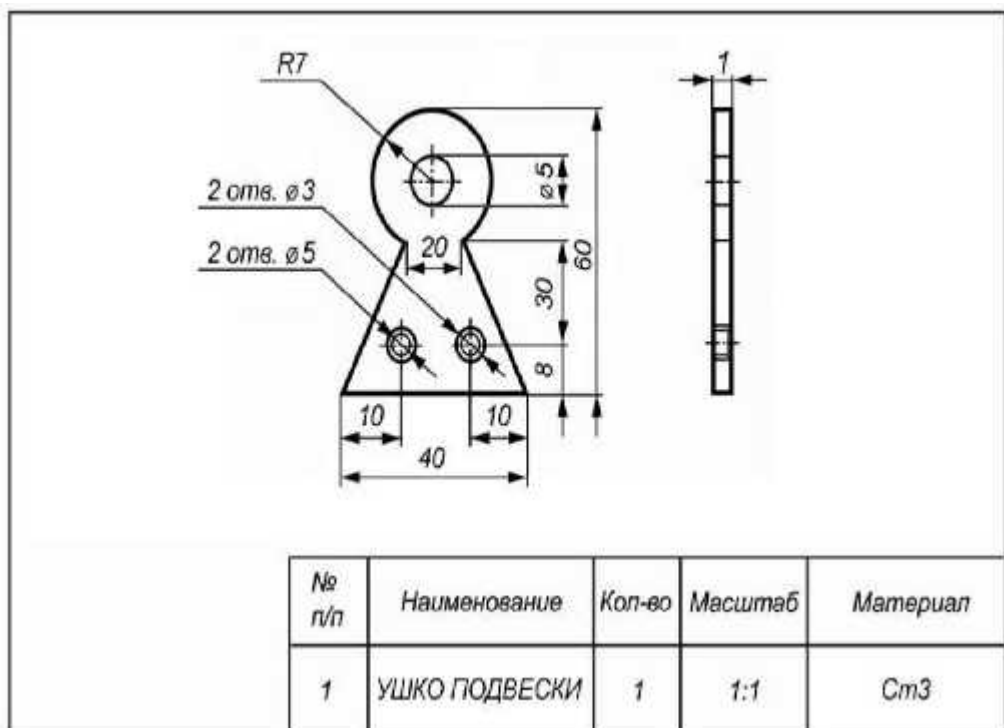

: ± 0,5

: 90

: ± 0,5

: 90

