



10-11

1 24 – 1 , (25) – 11 .

1. ?

))
))

2. ?

))
))

3. ?

) « »;
) ;
) ;
) .

4.

,
,
,
,
))

5.

)
)
)
)

6.

,
:
) ;) ;
) ;) .

7.

, _____ .



10-11

8.

?

: _____

9.

,

?

10.

:

-) ;
-) ;
-) ;
-) ;
-) ;
-) ;
-) ;
-) ;

11.

:

-) ;) .
-) ;

12.

,

_____ . _____

13.

_____ . _____

14.

?

-) ;
-) ;
-) ;
-) ;
-) ;



10-11

15.

-) _____ ;
-) _____ ;
-) _____ ;
-) _____ .

16.

-) _____ , _____ ;
-) _____ ;
-) _____ ;
-) _____ ;
-) _____ ;
-) _____ ;
-) _____ ;
-) _____ ;
-) _____ ;
-) _____ .

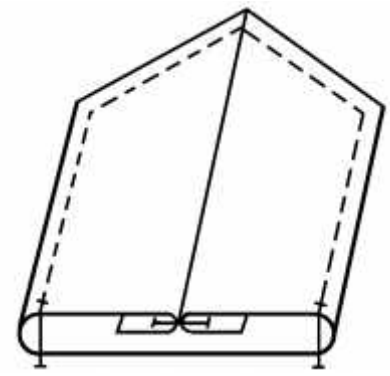

: 1 - «___», 2 - «___», 3 - «___», 4 - «___», 5 - «___», 6 - «___», 7 - «___», 8 - «___».

17.

	1
	2



10-11

	3
	4
	5
	6 -

: 1 – «__», 2 – «__», 3 – «__», 4 – «__», 5 – «__», 6 – «__».

18.

)

:

,

- _____,

)

:

,

()

,

- _____.



10-11

19.

-)
-)
-)
-)
-)
-)
-)

20.

-)
-)
-)
-)
-)
-)

21.

-)
-)

22.

-)
-)
-)

23.

500000 .

« 27,6% » .

?

-) 500000,
-) 568000,
-) 638000,
-) 6900000.

24.

.	1. >
.	2. <
.	3. =

: 1 - «___», 2 - «___», 3 - «___».



10-11

25.

, (),
:

- -
_____,
- -
_____,
- -
_____,
- -
_____,
- -
_____,
- -
_____.

